

## **FPSP5510GL-40D**

# **10G SFP+ Duplex 1550nm 40KM Transceiver Module**

### **Features**

- ✧ Compliant to SFP+MSA
- ✧ 1550nm Cooled EML Transmitter,APD photo-detector receiver
- ✧ SM 9/125um up to 40Km
- ✧ Duplex LC connector
- ✧ Built-in digital diagnostic monitoring functions
- ✧ All-Metal housing for superior EMI Performance
- ✧ Power dissipation 1.5W typical (Maximum:2W),Single 3.3V power supply
- ✧ Operating Case Temperature Standard: -5°C~+70°C
- ✧ Electronic Interface compliant with SFF-8431
- ✧ Digital Diagnostic Monitor Function Compatible with SFF-8472
- ✧ 10GBASE-ZR,and 2G/4G/8G/10G Fiber Channel applications
- ✧ ROHS6 Compliant



### **Applications**

- ✧ 10G Ethernet
- ✧ 10G Fiber Channel

### **Product Description**

Fiberpon's FPSP5510GL-40D Transceiver is a "Limiting module", designed for 10G Ethernet, and 2G/4G/ 8G/10G Fiber- Channel applications.

The transceiver consists of two sections: The transmitter section incorporates a colded EML laser.

And the

receiver section consists of a APD photodiode integrated with a TIA. All modules satisfy class I

laser safety

requirements. Digital diagnostics functions are available via a 2-wire serial interface, as specified in

SFF-8472, which allows real-time access to device operating parameters such as transceiver temperature,

laser bias current, transmitted optical power, received optical power and transceiver supply voltage.

## Absolute Maximum Ratings

Parameter	Symbol	Min.	Typ.	Max.	Unit
Storage Temperature	Ts	-40		85	°C
Supply Voltage	VCC	-0.5		3.6	V

## Recommended Operating Conditions

Parameter	Symbol	Min.	Typ.	Max.	Unit
Ambient Operating Temperature	TBB <sub>ABB</sub>	-5		70	°C
Supply Voltage	VCC	3.15	3.3	3.45	V
Supply Current	ICC		425	610	mA
Module Power Dissipation	Pm		1.5	2	W
Data Rate	Mra		10.3	11.1	Gpbs

## Electrical Characteristics

Parameter	Symbol	Min.	Typ.	Max.	Unit	Notes
<b>Transmitter</b>						
Input differential impedance	Ri		100		Ω	1
Differential data input swing	V <sub>in,pp</sub>	120		850	mV	
Transmit disable voltage	VD	2		V <sub>cc</sub>	V	
Transmit enable voltage	VEN	0		+0.8	V	
Transmit disable assert time	Vn			100	us	
<b>Receiver</b>						
Differential data output swing	V <sub>out,pp</sub>	350		850	mV	
Data output rise time,fall time	tr	24			P	2
Los Fault	VLOS fault	2		V <sub>cc</sub> +0.3	V	3

Los Normal	VLOS norm	Vee		Vee+0.8	V	3
------------	-----------	-----	--	---------	---	---

**Notes:**

1. Connected directly to TX data input pins, AC coupling from pins into laser drive
2. 20 – 80 % . Measured with Module Compliance Test Board and OMA test pattern. Use of four 1’s and four 0’s in sequence in the PRBS<sup>9</sup> is an acceptable alternative. SFF-8431 Rev 2.1
3. LOS is an open collector output. Should be pulled up with 4.7kΩ – 10kΩ on the host board. Normal operation is logic 0; loss of signal is logic 1. Maximum pull-up voltage is 3.6V

**Optical Characteristics**

Parameter	Symbol	Min.	Typ.	Max.	Unit	Notes
<b>Transmitter</b>						
Center Wavelength	$\lambda_t$	1530	1550	1565	nm	
Average Optical Power	P <sub>av</sub>	-1		3	dBm	
Spectral Width(-20dB)	$\Delta\lambda_{20}$			0.3	nm	
Side Mode Suppression Ratio	SMSR	30			dB	
Extinction Ratio	ER	9			dB	
Relative Intensity Noise	RIN			-128	dB/Hz	
Optical Return Loss Tolerance	Orl			21	dB	
<b>Receiver</b>						
Center Wavelength	$\lambda_R$	1260		1620	nm	
Receiver Sensitivity 9.95~10.3125Gb/s	Rsen1			-15.5	dBm	1
Receiver Sensitivity 10.5~11.1Gb/s	Rsen2			-15	dBm	
Path penalty at 1600 ps/nm9.95~10.3125Gb/s	DP1		2	2.5	dBm	
Path penalty at 1600 ps/nm10.5~10.7Gb/s	DP2			3	dBm	
Path penalty at 1450 ps/nm~11.1Gb/s	DP3			3	dBm	
Receiver Overload	RPmax	0.8			dBm	2
LOS De-Assert	LOS <sub>D</sub>			-19	dBm	
LOS Assert	LOS <sub>A</sub>	-34			dBm	
LOS Hysteresis	Lh	0.5			dB	

**Notes:**

1. Measured with a PRBS  $2^{31}-1$  test pattern ,BER $\leq 10^{-12}$
2. Receiver Overload specified in OMA and under the worst comprehensive stressed conditions

## Pin function definitions

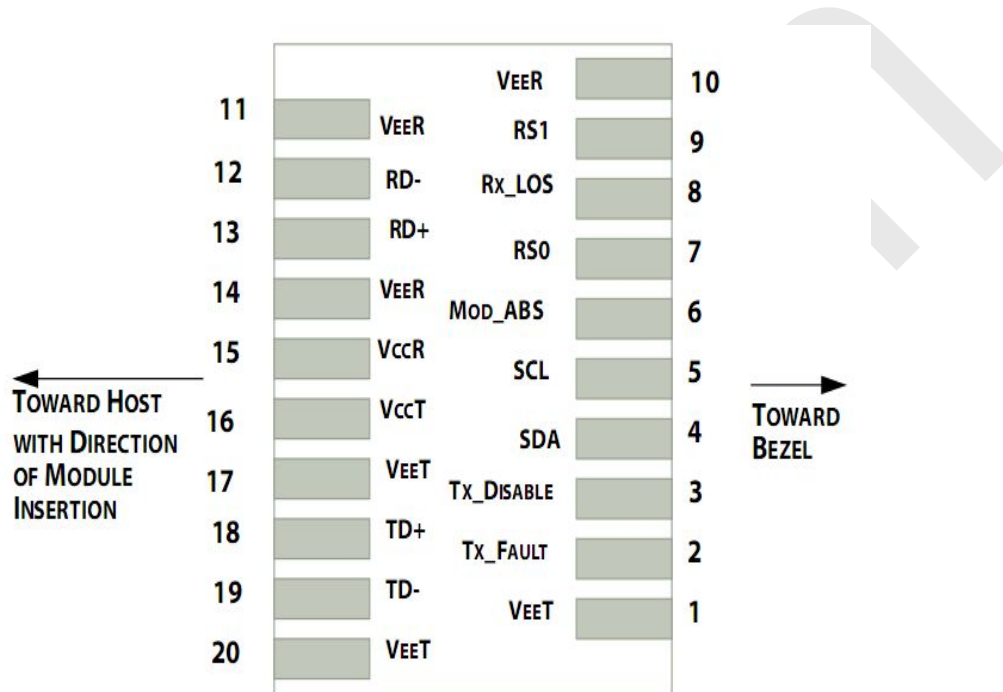

**Figure 1 Transceiver pin descriptions**

Pin Number	Symbol	Name/Description	Ref.
1	V <sub>EET</sub>	Transmitter Ground (Common with Receiver Ground)	1
2	T <sub>FAULT</sub>	Transmitter Fault.	2
3	T <sub>DIS</sub>	Transmitter Disable. Laser output disabled on high or open.	3
4	SDA	2-wire Serial Interface Data Line	4
5	SCL	2-wire Serial Interface Clock Line	4
6	MOD_ABS	Module Absent. Grounded within the module	4
7	RS0	No connection required	1
8	LOS	Loss of Signal indication. Logic 0 indicates normal operation.	5
9	RS1	No connection required	1
10	V <sub>EER</sub>	Receiver Ground (Common with Transmitter Ground)	1
11	V <sub>EER</sub>	Receiver Ground (Common with Transmitter Ground)	1
12	RD-	Receiver Inverted DATA out. AC Coupled	

13	RD+	Receiver Non-inverted DATA out. AC Coupled	
14	V <sub>EER</sub>	Receiver Ground (Common with Transmitter Ground)	1
15	V <sub>CCR</sub>	Receiver Power Supply	
16	V <sub>CCT</sub>	Transmitter Power Supply	
17	V <sub>EET</sub>	Transmitter Ground (Common with Receiver Ground)	1
18	TD+	Transmitter Non-Inverted DATA in. AC Coupled.	
19	TD-	Transmitter Inverted DATA in. AC Coupled.	
20	V <sub>EET</sub>	Transmitter Ground (Common with Receiver Ground)	1

**Notes:**

1. Circuit ground is internally isolated from chassis ground.
2. T<sub>FAULT</sub> is an open collector/drain output, which should be pulled up with a 4.7k-10k Ohms resistor on the host board if intended for use. Pull up voltage should be between 2.0V to Vcc+0.3V. A high output indicates a transmitter fault caused by either the TX bias current or the TX output power exceeding the preset alarm thresholds. A low output indicates normal operation. In the low state, the output is pulled to <0.8V.
3. Laser output disabled on T<sub>DIS</sub> >2.0V or open, enabled on T<sub>DIS</sub> <0.8V.
4. Should be pulled up with 4.7kΩ-10kΩ host board to a voltage between 2.0V and 3.6V. MOD\_ABS pulls line low to indicate module is plugged in.
5. LOS is open collector output. It should be pulled up with 4.7kΩ-10kΩ on host board to a voltage between 2.0V and 3.6V. Logic 0 indicates normal operation; logic 1 indicates loss of signal.

## Typical application circuit

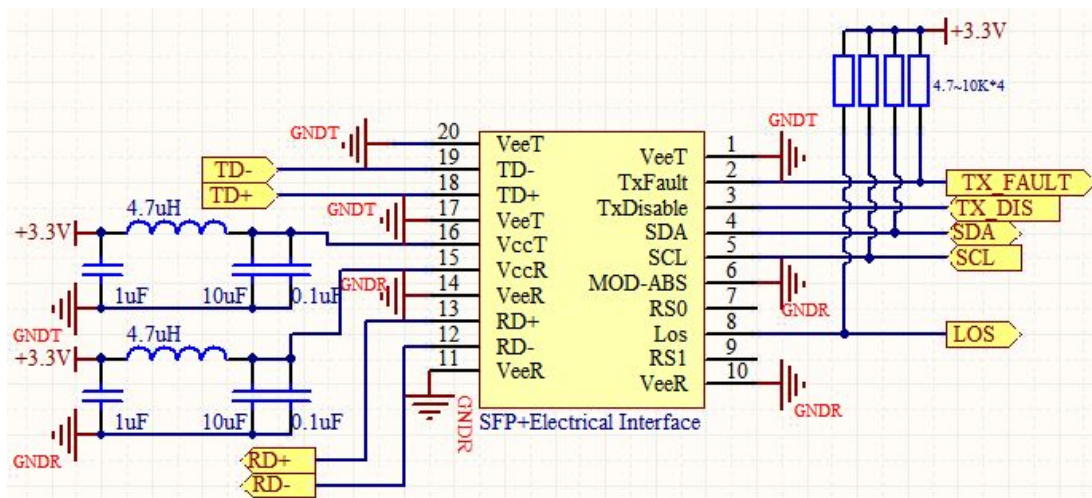

Figure 2 SFP+Electrical Interface

## Digital Diagnostic Functions

Fiberpon's FPSP5510GL-40D transceivers support the 2-wire serial communication protocol as defined in the SFP MSA.

The SFP MSA defines a 256-byte memory map in EEPROM that is accessible over a 2-wire serial interface at the 8 bit address 1010000X (A0h). The digital diagnostic monitoring interface makes use of the 8 bit address 1010001X (A2h).

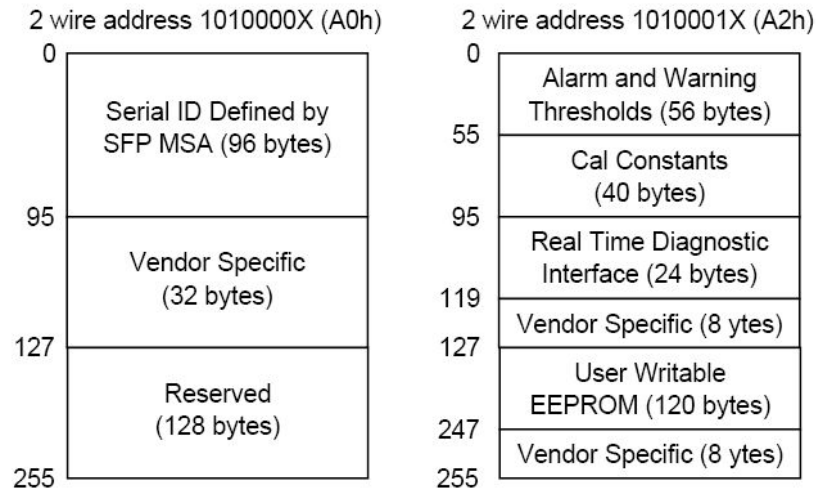
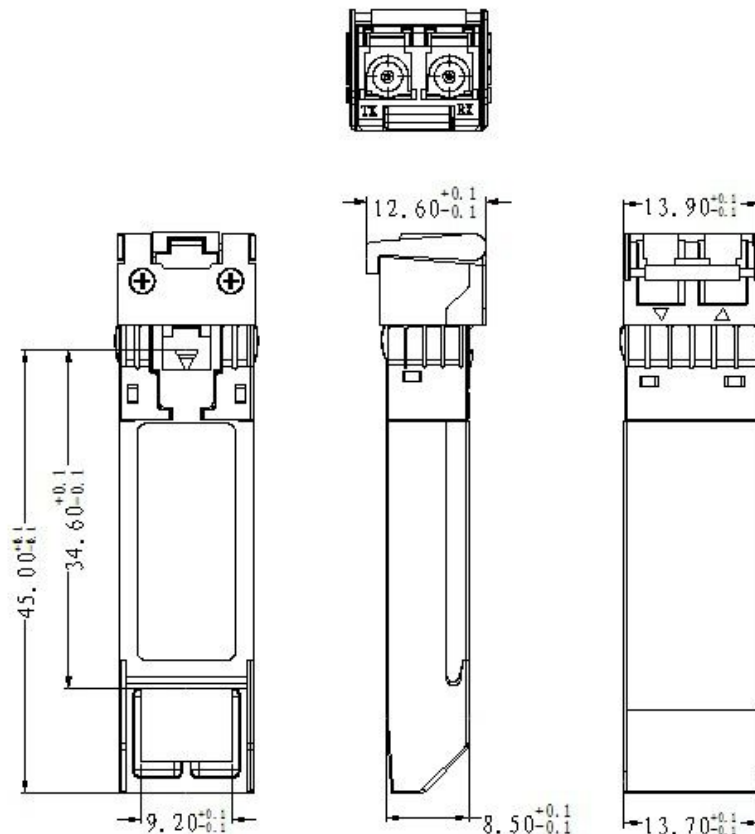

Figure 3 Digital Diagnostic Memory Map

## Mechanical Specifications



## ESD

This transceiver is specified as ESD threshold 2kV for all electrical input pins, tested per MIL-STD-883, Method 3015.4 /JESD22-A114-A (HBM). However, normal ESD precautions are still required during the handling of this module. This transceiver is shipped in ESD protective packaging. It should be removed from the packaging and handled only in an ESD protected environment.

## Ordering information

Product Number	Data Rate	Laser	Receiver	Distance	Interface	DDM	Temp.
FPSP5510GL-40D	10Gbps	DFB	APD	40Km	LC	YES	C

**\* 40D--- 40Km with SM 9/125um Fiber Transmission, with DDM/DOM Functional**

## Notice

Performance figures, data and any illustrative material provided in this data sheet are typical and must be specifically confirmed in writing by Fiberpon before they become applicable to any particular order or contract. In accordance with the Fiberpon policy of continuous improvement specifications may change without notice. The publication of information in this data sheet does not imply freedom from patent or other protective rights of Fiberpon or others. Further details are available from any Fiberpon sales representative.